



PREMIER MOUNTS®

The original holding company™

TWIN DISPLAY STAND INSTALLATION INSTRUCTIONS

Product Contents

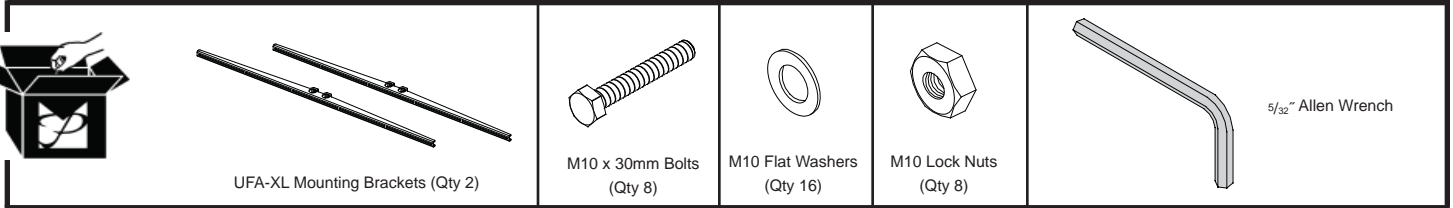

Installation Tools (not supplied)

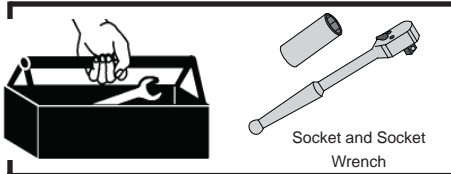

Optional Items (not included)

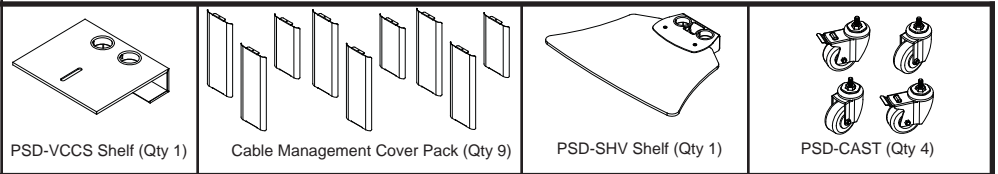

TWIN DISPLAY STAND FEATURES

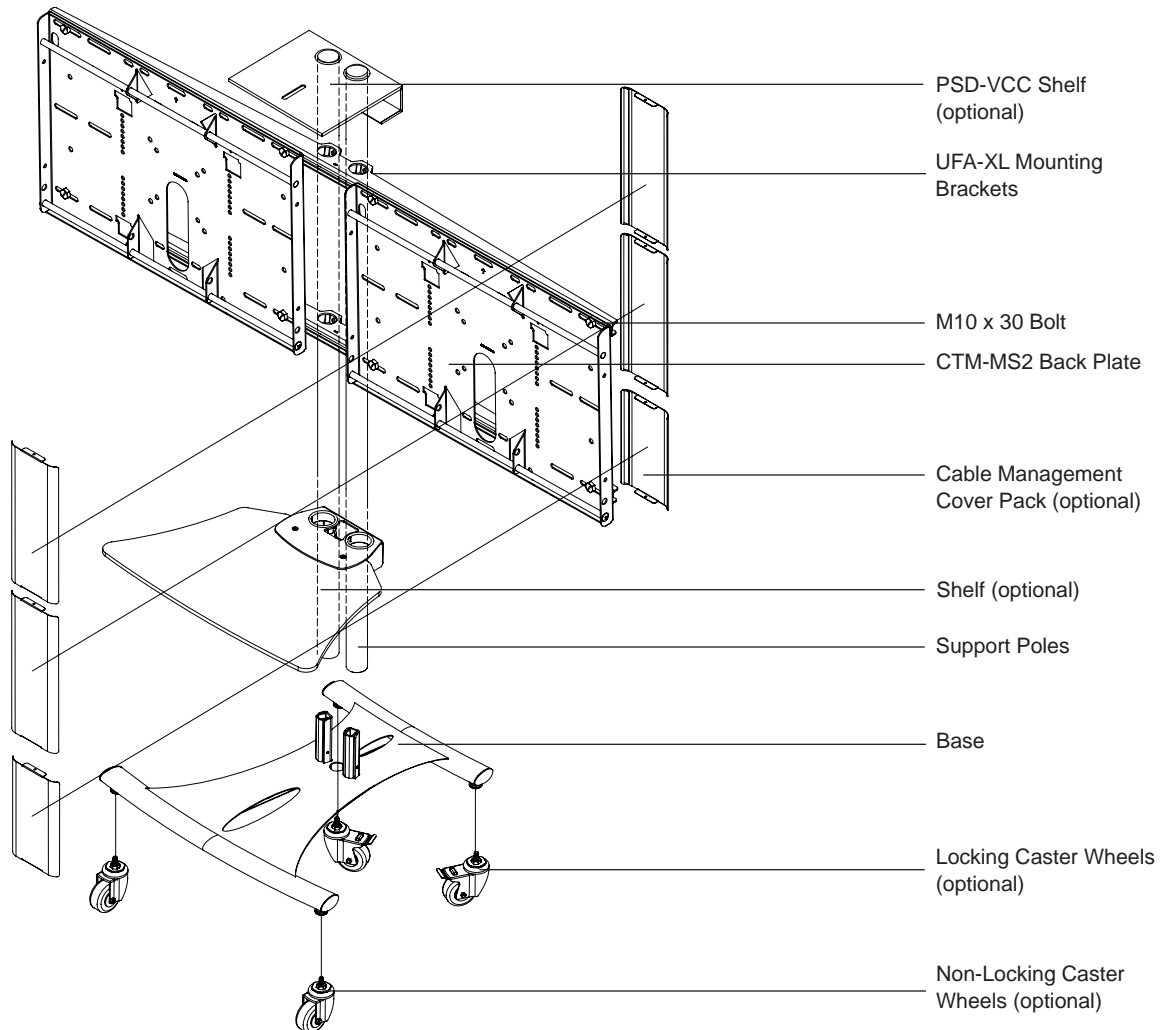



TWIN DISPLAY STAND INSTALLATION INSTRUCTIONS

- Please refer to the PSD-EB Installation Instructions when assembling this stand. Please follow all safety and warnings listed in the instructions.
- Please refer to the CTM-MS2 Installation Instructions when assembling CTM-MS2 Mount. Please follow all safety and warnings listed in the instructions.

Step 1

Prior to installing the UFA-XL mounting brackets, determine where the upper mounting bracket will be located.

Slide the first UFA-XL mounting bracket onto and down the support poles and let it rest on the base.

Slide the second UFA-XL mounting bracket onto the support poles.

Determine where you would like the upper UFA-XL mounting bracket to be located.

Once the position is determined, use a 5/32" Allen Wrench to tighten the two (2) set screws that are located on the back of the UFA-XL.

Do NOT over-tighten these screws.

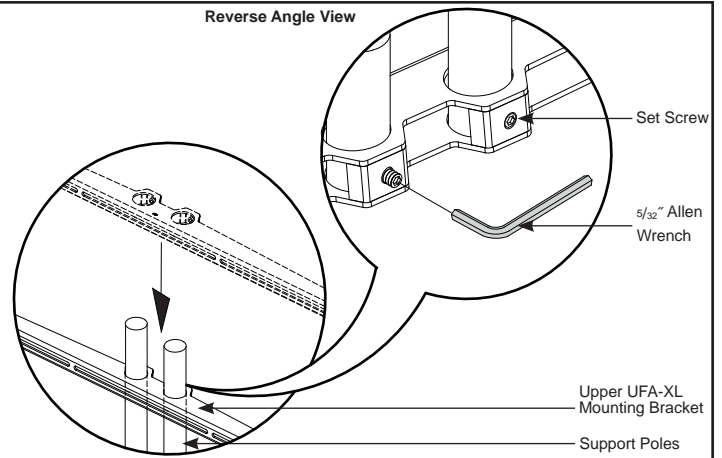

Step 2

Place the CTM-MS2 back plate against the upper UFA-XL mounting bracket and align the mounting slots.

Insert two (2, one for each side) M10 x 30 bolts, thread on one (1) flat washer and one (1) M10 lock nut. Tighten using a socket and socket wrench.

Slide the lower UFA-XL mounting bracket up and align the lower mounting slots with the CTM-MS2. Repeat the previous step for securing the CTM-MS2 back plate to the lower UFA-XL mounting bracket.

Use a 5/32" Allen Wrench to tighten the two (2) set screws that are located on the back of lower the UFA-XL. Install the remaining CTM-MS2 back plate at this time.

Install the flat panels at this time (see above).

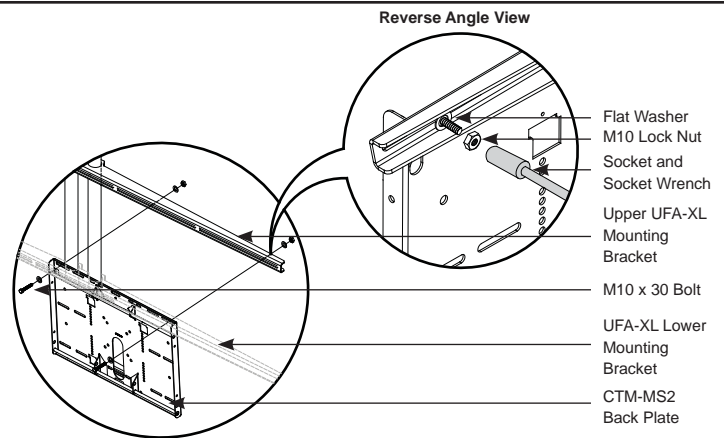

Step 3

There must be 15cm of space between the UFA-XL and the top of the support poles if the optional VCC shelf is used.

Slide the VCC shelf (optional) onto and down the support poles.

Adjust the VCC shelf so that it will be mounted just above the top edge of the flat panel.

Use a 5/32" Allen Wrench to tighten the four (4) set screws that are located on the back of the VCC shelf.

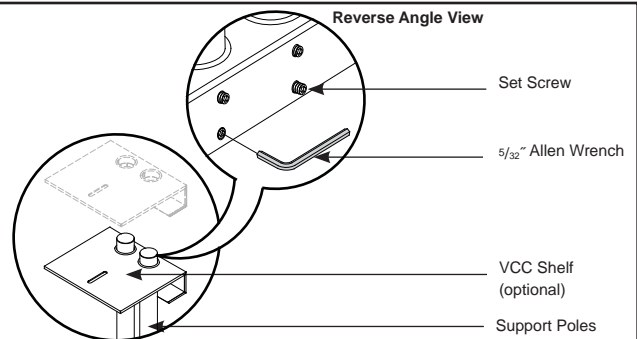

WARNING

CAN TIP OVER RESULTING IN RISK OF INJURY. DO NOT ALLOW CHILDREN UNDER 16 TO MOVE CART. MOVE CART SLOWLY.

ONLY ADULTS SHOULD MOVE THIS UNIT.

APPLY MOVING FORCE ON NARROW DIMENSION.

NEVER APPLY FORCE AT TOP. ALWAYS PUSH NEAR MIDDLE.

PUSH, DON'T PULL.



THE FLOOR STRUCTURE MUST BE CAPABLE OF SUPPORTING AT LEAST 250 LBS. IF NOT, THE FLOOR STRUCTURE MUST BE REINFORCED. PROPER INSTALLATION PROCEDURE BY A QUALIFIED SERVICE TECHNICIAN, AS OUTLINED IN THE INSTALLATION INSTRUCTIONS, MUST BE ADHERED TO. FAILURE TO DO SO COULD RESULT IN SERIOUS PERSONAL INJURY, OR EVEN DEATH.

NORTH AMERICA

3130 East Miraloma Avenue
 Anaheim, CA 92806 USA
 USA and Canada –
 Phone: 800-368-9700
 Fax: 800-832-4888

EUROPE

Swallow House,
 Shilton Industrial Estate,
 Shilton, Coventry, England CV79JY
 Phone: +44 (0) 2476 614700
 Fax: +44 (0) 2476 614710

WARNING

DO NOT load the Cart/Stand past the maximum weight capacity. DO NOT mount a flat panel larger than the recommended size. Failure to comply with warning may result in Cart/Stand instability leading to equipment damage or personal injury.