

### Overview

- Enables extension of 480 mm and retraction back against the wall
- Infinite positioning of your monitor for the most adequate viewing angle
- Monitor pivot adjustment of 360 degrees (Landscape/Portrait function)
- VESA® FDMI™ standard compliant
- Easy and stable mounting on a wall surface
- Solid and durable steel construction, powder coated
- Improve ergonomics and comfort at home and in your workplace
- 10 years warranty



FOR OFFICE & HOME

## GD01

### Universal LCD/TFT monitor wall-mounted arm (14-22")



GD01 is a LCD/TFT Swing Arm Wall Mount. It increases ergonomics and comfort at workplaces and gives an opportunity to free up desk space. The wall mount is VESA standard compliant with VESA® FDMI™ standard 75x75mm and 100x100mm\*.

GD01 LCD/TFT swing arm mounted in desired position, ensures infinite positioning of your monitor for the most adequate viewing angle.

LCD/TFT monitor can be extended 480 mm from the wall and retracted against the wall when it is not longer needed.

\*The optional component GDA1 provides a 200x100mm mounting interface.



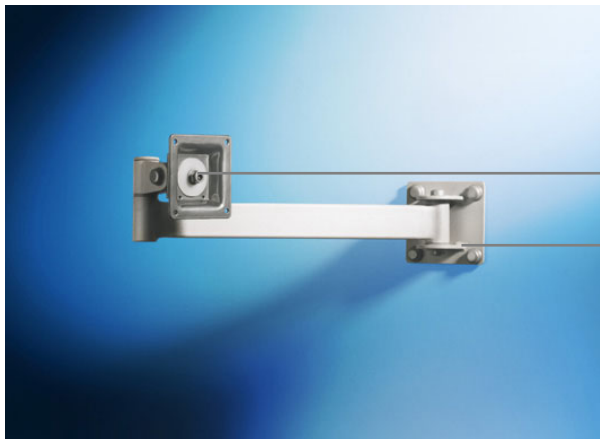

VESA Adapter

Wall mounting plate

## Range of movement

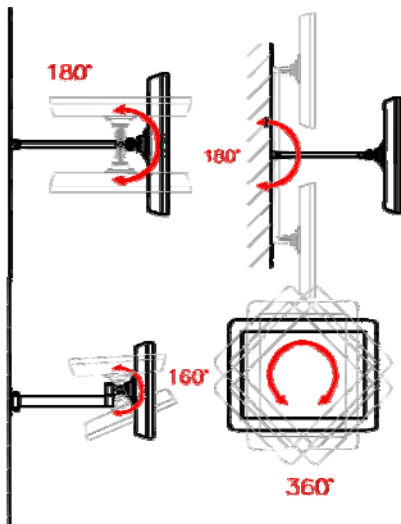

## Dimensions

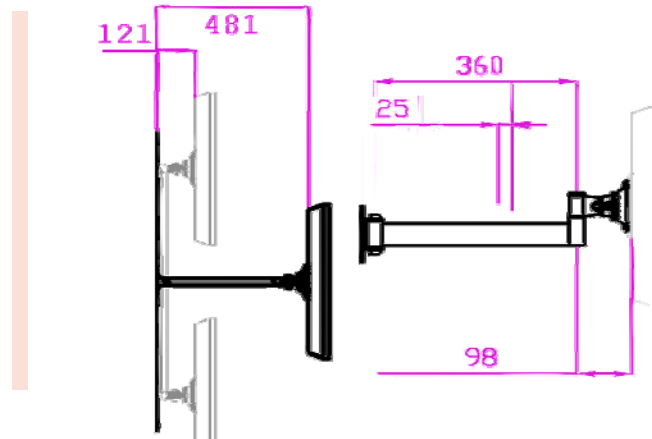

## Technical data

<b>Load capacity:</b>	up to 10kg
<b>Mounting interface:</b>	75mm x 75mm
<b>VESA FDMI MIS-D:</b>	100mm x 100mm
<b>Max. / min. Distance to the wall</b>	481mm / 121mm
<b>Option GDA1 (not supplied)</b>	200 x 100mm
<b>Net weight (Gross):</b>	2,4 (2,7) kg
<b>Packaging dimensions:</b>	420x130x130mm

Order Code:	Available Colours:	Type of packaging:	EAN product code:
<b>GD01c-B</b>	Black (RAL9005)	Brown	5908252960279
<b>GD01s-B</b>	Silver (RAL9006)	Brown	5908252960286
<b>GDA1s-B</b>	Silver (RAL9006 Glossy)	Brown	5908252960293

© 2006 EDBAK Sp. z o.o.

16.06.2006

EDBAK Sp. z o.o.

Piotrowice 186, 23-107 Strzyżewice  
Poland  
tel. +48 81 562 81 19  
tel./fax +48 81 562 82 90  
e-mail: info@edbak.com

www.edbak.com



Quality Management System in  
compliance with ISO 9001.