

Overview

- *Universal Fixed Wall Mount for 22-32" plasma / LCD screens and a load capacity of up to 60kg*
- *Quick and easy installation*
- *Solid steel construction, powder coated*
- *Security screw holds the screen in exact position*
- *Back plate has several holes for mounting on brick, concrete and stud walls*
- *Fits VESA standards 75x75, 100x100, 200x100, 200x200 or 400x200mm*
- *Packaging includes screws and spacers for different TV makes and models*
- *After mounting screen hangs like a picture on the wall*
- *Distance to the wall is reduced to a minimum*
- *10 years warranty*

Optional Adapters

- **SAL1**
- **CM1**
- **TR1 / TR2 / TR3**
- **SFP1**

FOR HOME & OFFICE

LWB1

Universal Fixed Wall Mount for Plasma / LCD screens (22-32")



LWB1 is an universal fixed wall mount for 22-32" plasma / LCD screens with a load capacity of up to 60kg. Its design ensures quick, easy and safe installation*:

LWB1 consists of a back plate that can be fixed to a brick, stud or concrete wall and the two front plates that are mounted to the back of the screen.

The screen together with the front plates can be comfortably hooked to the back plate. The universal bracket contains also two security screws in order to keep the screen in position.

Included in the box are screws and spacers for different TV makes and models.

*LWB1 can be fixed directly to the wall or can be used with adaptors for swing arm, trolley or ceiling mount adaptors.



LWB1 Product card



Front plate

Back plate

Technical data

Load capacity:	Up to 60 kg
Dimensions:	540x300x45mm
Max. / Min. Mounting interface (width x height):	490x265mm / 50x75mm
Fits VESA standards:	75x75, 100x100, 200x100, 200x200, 400x200mm
Packaging dimensions:	570x180x45mm
Net weight (gross):	2,7(3,1) kg

Order Code:	Available Colours:	Type of packaging:	EAN product code:
LWB1c-R	Black (RAL9005)	Retail	5908252960040
LWB1s-R	Silver (RAL9006)	Retail	5908252960057
LWB1c-B	Black (RAL9005)	Brown	5908252960194
LWB1s-B	Silver (RAL9006)	Brown	5908252960200

Dimensions

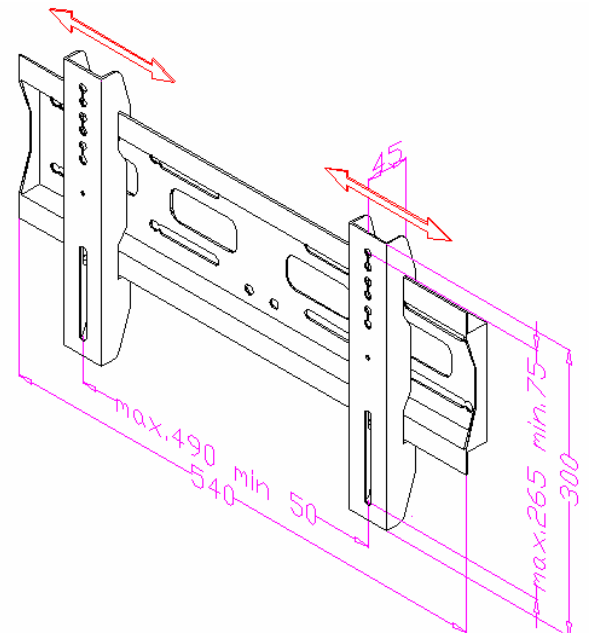

© 2007 EDBAK Sp. z o.o.

20.07.2007

EDBAK Sp. z o.o.

Piotrowice 186, 23-107 Strzyżewice
Poland
tel. +48 81 562 81 19
tel./fax +48 81 562 82 90
e-mail: info@edbak.com

www.edbak.com



EDBAK's Quality Management System
complies with ISO 9001:2000 standards
and it is certified by United Registrar of
Systems.



CERTIFICATE NO. 19264