

Overview

- *Universal Fixed Wall Mount for 60" and larger plasma / LCD screens and a capacity load of up to 110kg*
- *Quick and easy installation*
- *Solid steel construction, powder coated*
- *Security screw holds the screen in position*
- *Back plate has several holes for mounting on brick, concrete and stud walls*
- *Packaging includes screws and spacers for different TV makes and models*
- *After mounting, screen hangs like a picture and distance to the wall is reduced to a minimum*
- *Solid steel construction, powder coated*
- *10 years warranty*

XWB1

Universal Fixed Wall Mount for 60" and larger plasma / LCD screens with large mounting interface



XWB1 is an universal fixed wall mount for 60" and larger plasma / LCD screens with a capacity load of up to 110 kg. Its design ensures quick, easy and safe installation*:

XWB1 consists of a back plate that can be fixed to a brick, stud or concrete wall and the two front plates which are mounted to the back of the screen.

The screen together with the front plates can be comfortably hooked to the back plate. The universal bracket contains also two security screws in order to keep the screen in position.

This universal bracket was especially designed to fit TV makes and models that require a large mounting interface and a heavy duty capacity load.

Included in the box are screws and spacers for different TV makes and models.

*XWB1 can be fixed directly to the wall or can be used with adaptors for swing arm, trolley or ceiling mount adaptors.

XWB1 Product card



Safety Features

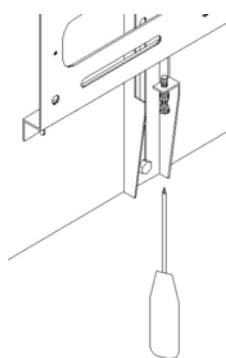

Dimensions

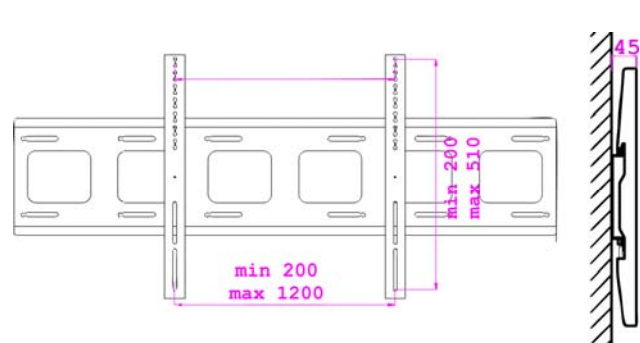

Technical data

Capacity load:	Up to 110 kg
Dimensions:	1260x540x45 mm
Max. / min. mounting interface (width x height):	1200x510 / 200x200mm
Screen size:	+ 60"
Max. distance to wall:	45mm
Dimensions of packaging:	1270x260x45mm
Net weight (gross):	10,7 (11,3) kg

Order Code:	Available Colours:	Type of packaging:	EAN product code:
XWB1c-B	Black (RAL9005)	Brown	5908252960897
XWB1s-B	Silver (RAL9006)	Brown	5908252960903

© 2006 EDBAK Sp. z o.o.

16.06.2006

EDBAK Sp. z o.o.

Piotrowice 186, 23-107 Strzyżewice
Poland
tel. +48 81 562 81 19
tel./fax +48 81 562 82 90
e-mail: info@edbak.com

www.edbak.com



EDBAK is certified according to the
ISO 9001 specification.